

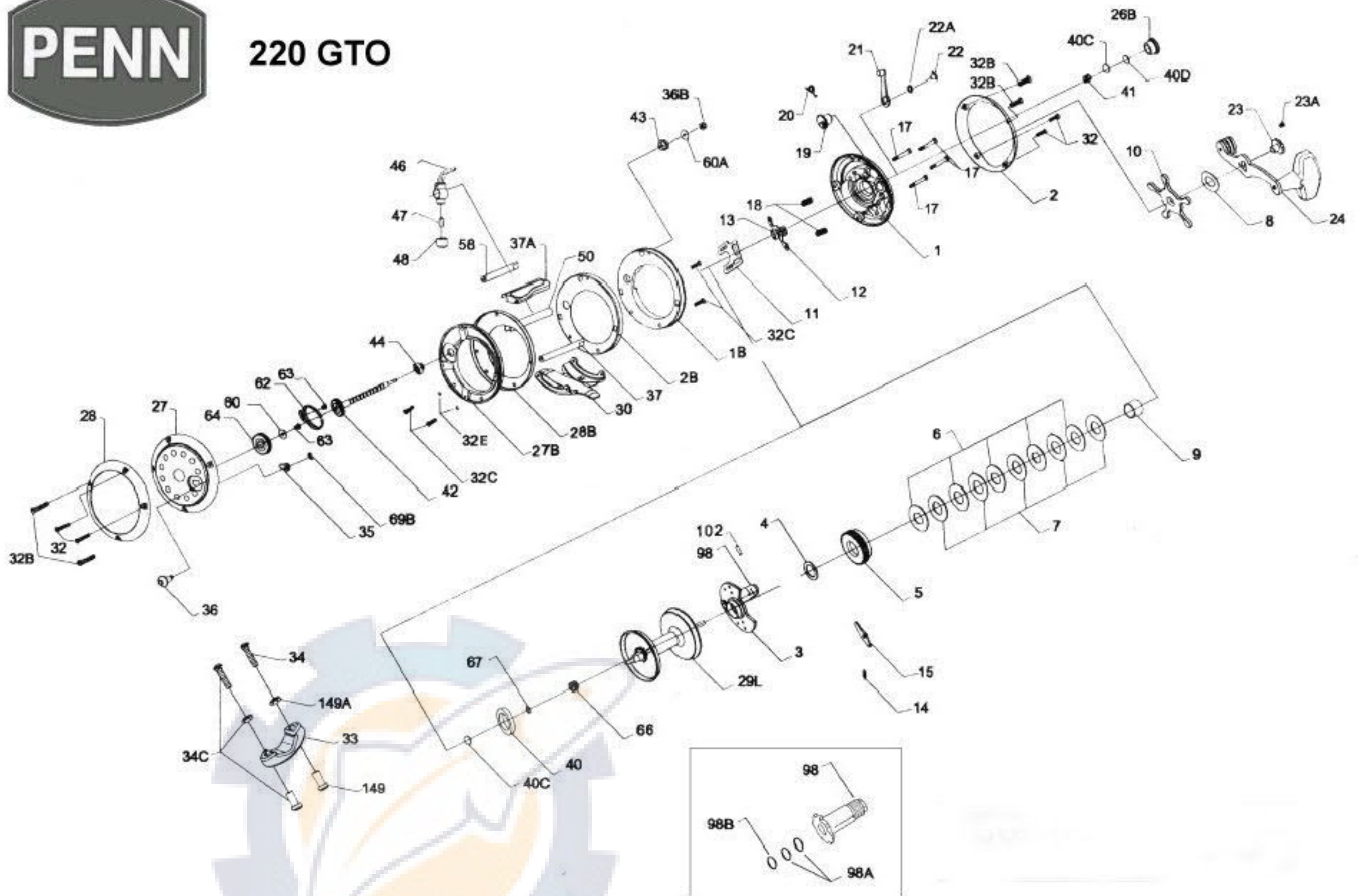

220 GTO



Penn Reel Parts list for Model: 220GTO LEVELWIND

KEY NO.	PART NO.	DESCRIPTION	KEY NO.	PART NO.	DESCRIPTION
1	1-220	R S OUTER PLATE	32B	32B-220	POST SCREW (4 REQ.)
1B	1B-220	R S INNER PLATE	32C	32C-220	STAND SCREW (4 REQ.)
2	2-220	R S OUTER RING	**32E	32E-220	STAND SCREW WASHER (4 REQ.)
2B	2B-220	R S INNER RING	33	33-220	RCD CLAMP
3	3-220	BRIDGE ASSEMBLY	34	34-220	CLAMP SCREW (2 REQ.)
4	4-349	FIBER WASHER	34C	34C-220	CLAMP SCREW/WALNUTS (2 REQ.)
5	5-220	MAIN GEAR	35	35-220	CLICK TONGUE
6	6-320	FRICTION DRAG WASHER (5 REQ.)	36	36-220	CLICK BUTTON
7	7C-220	METAL DRAG WASHER SET	36B	36B-220	WORM SHAFT NUT
8	8-220	TENSION SPRING	37	37-220	FRAME POST
9	9-220	SPACING SLEEVE	37A	37A-220	TOP SPACER BAR
10	10-220	STAR DRAG	40	40-220	BALL BEARING
11	11-220	ECCENTRIC JACK	40C	40C-220	METAL THRUST WASHER (2 REQ.)
12	12-220	PINION YOKE	40D	40D-220	RUBBER THRUST WASHER
13	13-220	PINION GEAR	41	41-220	R S THRUST BEARING SPRING
14	14-220	DOG SPRING	42	42-220	WORM
15	15-220	DOG	43	43-220	R S WORM BUSHING
17	17-220	BRIDGE SCREW (4 REQ.)	44	44-220	L S WORM BUSHING
18	18-220	CLUTCH SPRING (2 REQ.)	46	46-220	LINE GUIDE CARRIAGE
19	19-220	ECCENTRIC CAM	47	47-220	PAIWL
20	20-220	ECCENTRIC SPRING	48	48-220	PAIWL COVER SCREW
21	21-220	ECCENTRIC LEVER	50	50-220	WORM SHIELD
22	22-220	ECCENTRIC SCREW	58	58-220	SLOTTED POST
**22A	22A-220	ECCENTRIC SCREW/WASHER	60	60-220	IDLER GEAR WASHER
23	23-220	HANDLE SCREW	60A	60A-220	WORM NUT WASHER
23A	23A-220	HANDLE LOCK SCREW	62	62-220	CLICK SPRING
24	24-220	HANDLE	63	63-220	CLICK SPRING SCREW (2 REQ.)
26B	26B-220	SPOOL TENSION CONTROL CAP	64	64-220	IDLER GEAR
27	27-220	L S OUTER PLATE	66	66-220	SPOOL GEAR
27B	27B-220	L S INNER PLATE	67	67-220	SPOOL GEAR LOCK RING
28	28-220	L S OUTER RING	69B	69B-220	RETAINING RING / CLICK BUTTON
28B	28B-220	L S INNER RING	98	98-220	GEAR SLEEVE
29L	29L-220	SPOOL, ALUMINUM	**98A	98A-220	GEAR STUD SHIM (2 REQ.)
30	30-220	STAND	**98B	98B-220	GEAR STUD SHIM (1 REQ.)
32	32-220	SIDE PLATE SCREW (4 REQ.)	102	102-220	GEAR SLEEVE PIN
			149	149-220	CLAMP NUT (2 REQ.)
			149A	149A-220	HEX NUT (2 REQ.)